

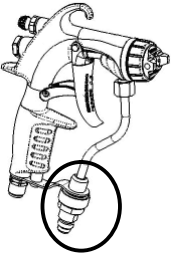
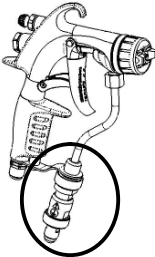
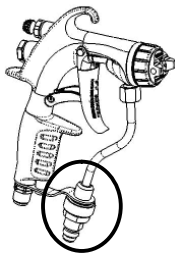
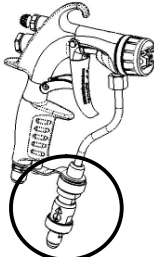
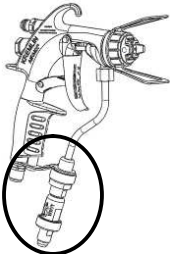

XCITE™

NOTICE ORIGINALE
/ TRANSLATION FROM THE ORIGINAL MANUAL
/ ÜBERSETZUNG DER ORIGINAL BETRIEBSANLEITUNG
/ TRADUCCIÓN DEL LIBRO ORIGINAL

<p><u>120 bar / 1740 psi</u> # 135.720.120</p>  <p><u>Avec filtre en ligne</u> <u>With inline filter</u> <u>Mit inline filter</u> <u>Con filtro en línea</u></p>	<p><u>120 bar / 1740 psi</u> # 135.720.100</p>  <p><u>Avec raccord tournant</u> <u>With swivel fitting</u> <u>Mit Drehgelenk</u> <u>Con racor giratorio</u></p>	<p><u>200 bar / 2900 psi</u> # 135.720.220</p>  <p><u>Avec filtre en ligne</u> <u>With inline filter</u> <u>Mit inline filter</u> <u>Con filtro en línea</u></p>	<p><u>200 bar / 2900 psi</u> # 135.720.200</p>  <p><u>Avec raccord tournant</u> <u>With swivel fitting</u> <u>Mit Drehgelenk</u> <u>Con racor giratorio</u></p>	<p>↻ 2 - 4</p>
<p><u>400 bar / 5800 psi</u> # 135.720.400</p>  <p><u>Avec filtre en ligne & raccord tournant SFS</u> <u>With inline filter & SFS swivel fitting</u> <u>Mit inline filter & SFS-Drehgelenk</u> <u>Con filtro en línea & racor giratorio SFS</u></p>				<p>↻ 5 - 7</p>
<p><u>Tableau des buses / Tip chart / Düsentabelle / Cuadro de las boquillas</u></p> 				<p>↻ 8</p>

120 bar / 1740 psi & 200 bar / 2900 psi

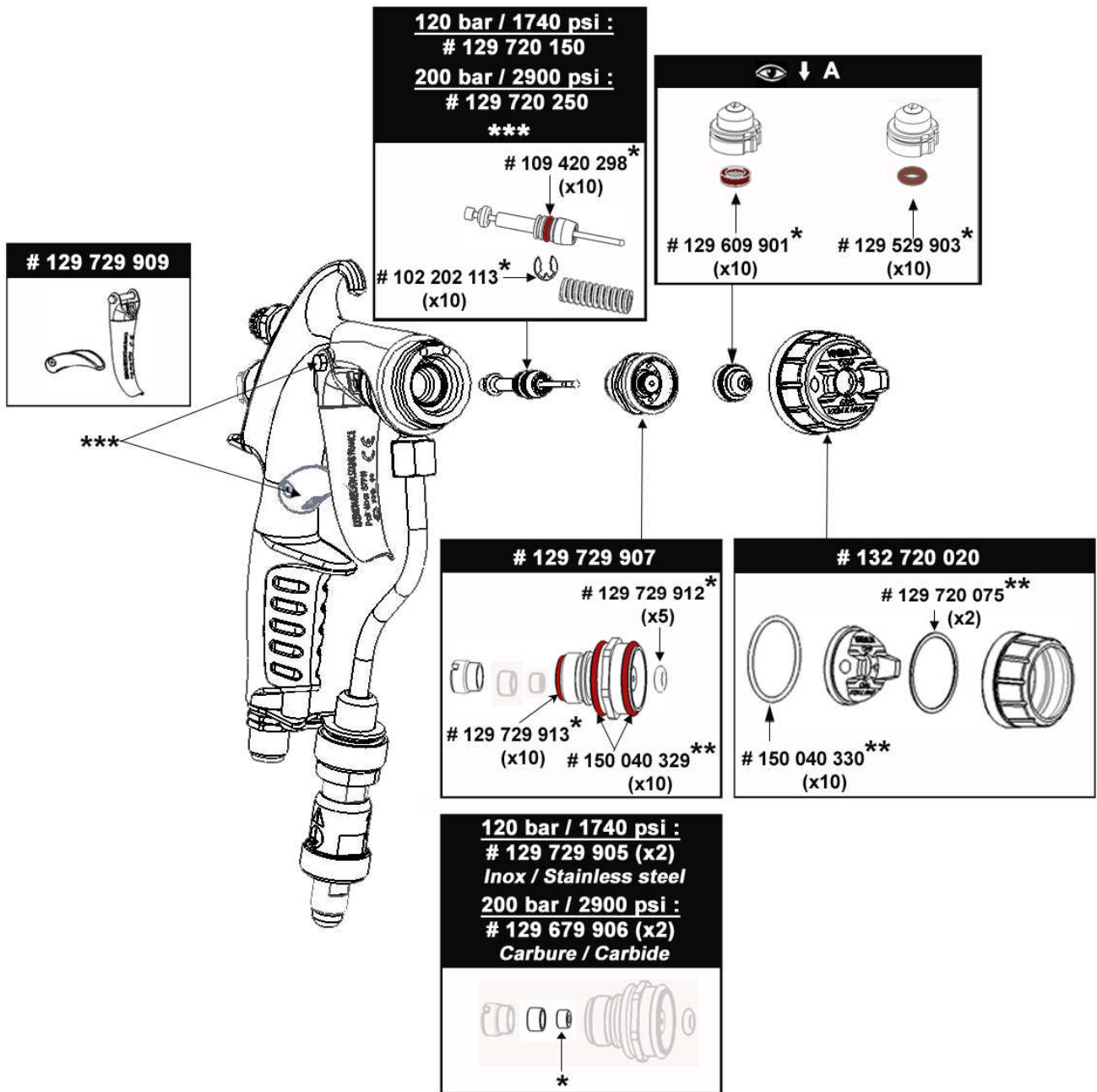

* Pochette de joints - produit / Paint seal kit
Dichtungssatz - Material / Bolsa de juntas - producto

** Pochette de joints - air / Air seal kit
Dichtungssatz - Luft / Bolsa de juntas - aire

*** Pochette maintenance / Servicing kit
Reparatursatz / Bolsa de reparación

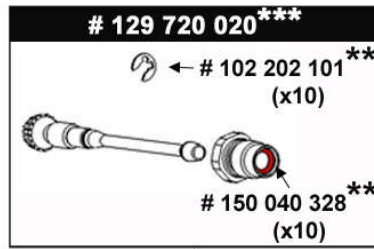

Kit 120 bar / 1740 psi
129 729 910

C+D+E+F

Kit 200 bar / 2900 psi
129 729 911

C+D+G+H

120 bar / 1740 psi : E
200 bar / 2900 psi : G

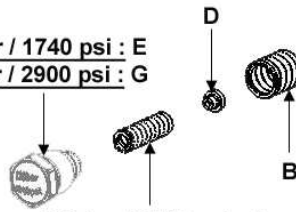

120 bar / 1740 psi : F
129 729 914 (x5)

200 bar / 2900 psi : H
129 729 915 (x5)
bleu / blue
blau / azul

129 720 030***

A+B

050 102 624

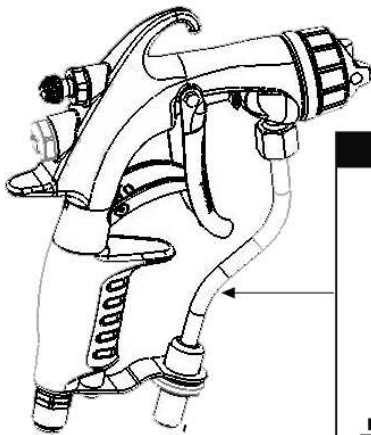

129 520 370

129 670 401

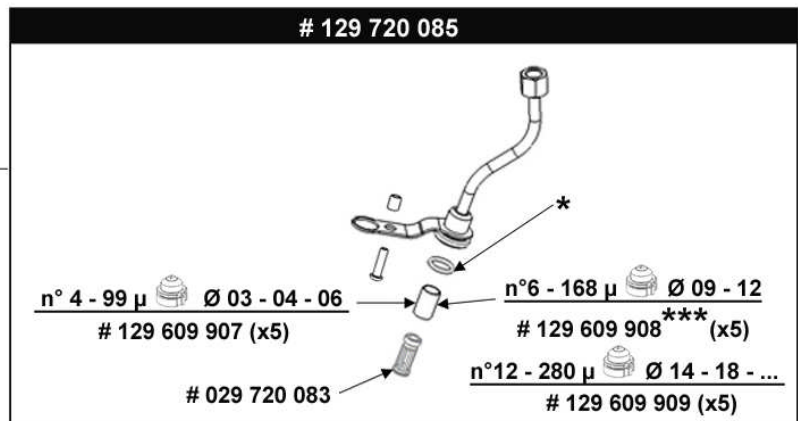

* Pochette de joints - produit / Paint seal kit
Dichtungssatz - Material / Bolsa de juntas - producto

** Pochette de joints - air / Air seal kit
Dichtungssatz - Luft / Bolsa de juntas - aire

*** Pochette maintenance / Servicing kit
Reparaturatz / Bolsa de reparación

OPTIONS / OPTIONAL / OPTIONEN / OPCIONES
120 bar / 1740 psi & 200 bar / 2900 psi

129 729 901
Produit / Paint



129 729 908
Air

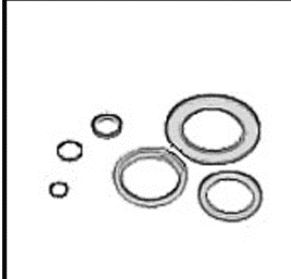

120 bar / 1740 psi
129 729 920
200 bar / 2900 psi
129 729 921



Produit / Paint

Air

129 729 904 (x10)
Acétale / Polyacetal

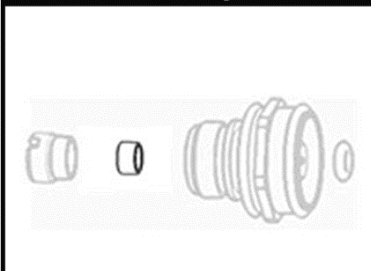

075 810 010
Longueur / Length : 400 mm



PMS / MWP :
Max 120 bar / 1740 psi

120 bar / 1740 psi
151 260 988
200 bar / 2900 psi
151 260 989
Ø 4,8 mm - 7,5 mm

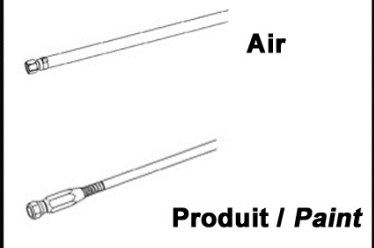

Air

Produit / Paint

049 030 042



906 300 101



Ø < 09 # 000 094 000
Ø ≥ 09 # 000 094 002

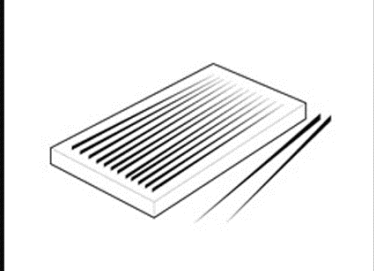

129 729 922



400 bar / 5800 psi

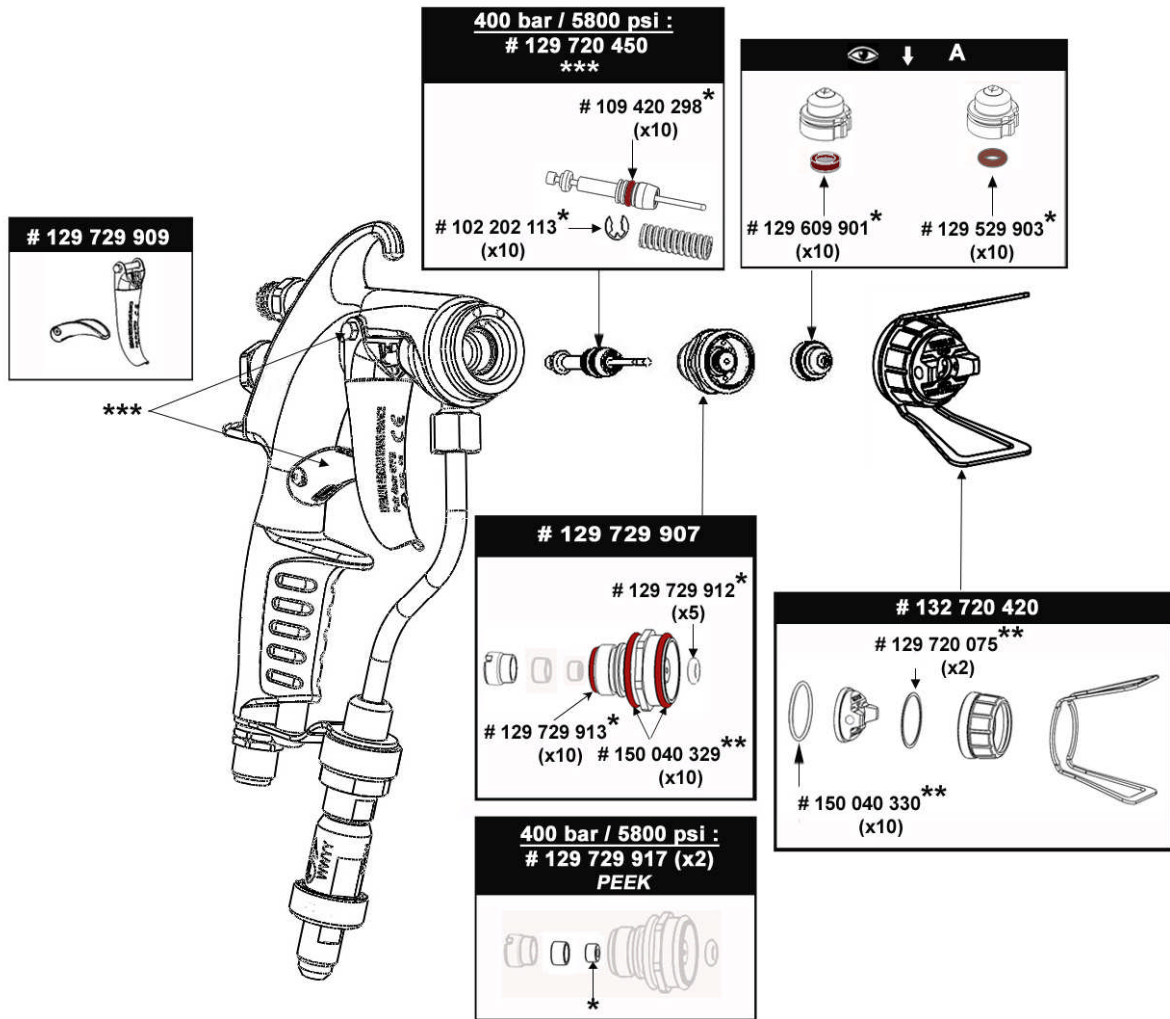

- * Pochette de joints - produit / Paint seal kit
Dichtungssatz - Material / Bolsa de juntas - producto
- ** Pochette de joints - air / Air seal kit
Dichtungssatz - Luft / Bolsa de juntas - aire
- *** Pochette maintenance / Servicing kit
Reparaturset / Bolsa de reparación

Kit 400 bar / 5800 psi
129 729 918
C+D+I+J

400 bar / 5800 psi : I

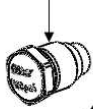

400 bar / 5800 psi : J
129 729 916 (x5)
rouge / red
rot / rojo

D



B



C

129 720 020***
 ← # 102 202 101**
 (x10)
 # 150 040 328**
 (x10)

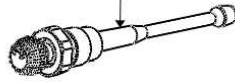

A

129 720 030***
A+B

050 102 624

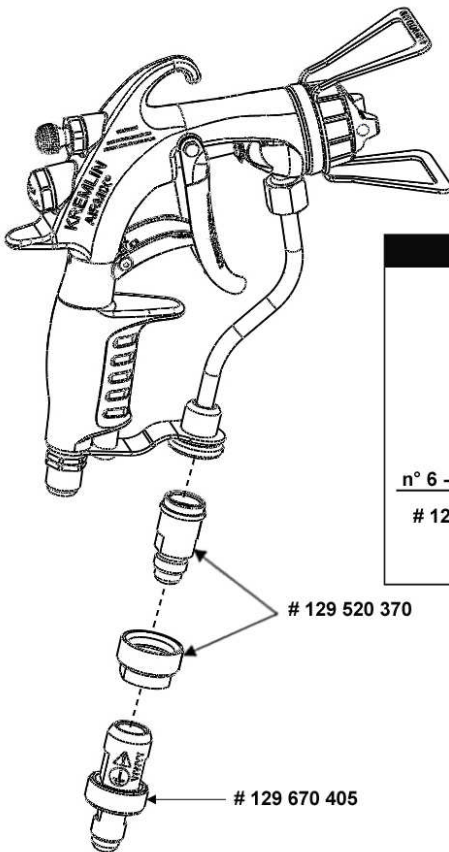
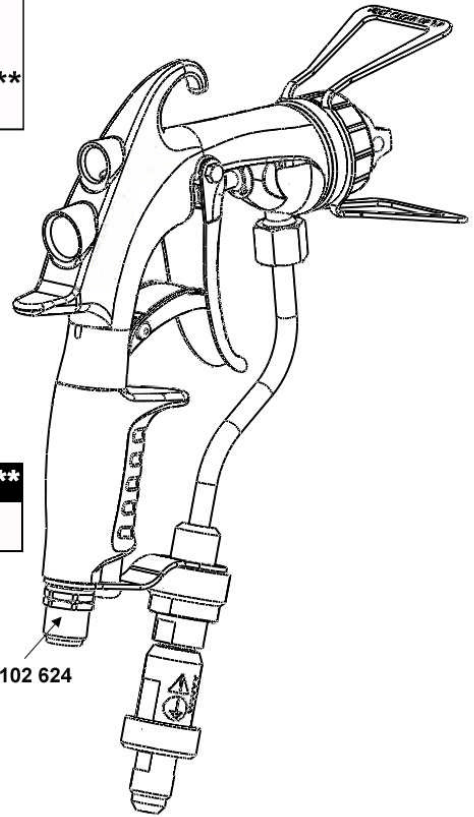

129 520 370

129 670 405

129 720 085

n° 6 - 168 μ Ø 09 - 12
 # 129 609 908*** (x5)

n° 4 - 99 μ Ø 03 - 04 - 06
 # 129 609 907 (x5)

n° 12 - 280 μ Ø 14 - 18 - ...
 # 129 609 909 (x5)

029 720 083

* Pochette de joints - produit / Paint seal kit
 Dichtungssatz - Material / Bolsa de juntas - producto
 ** Pochette de joints - air / Air seal kit
 Dichtungssatz - Luft / Bolsa de juntas - aire
 *** Pochette maintenance / Servicing kit
 Reparatursatz / Bolsa de reparación

OPTIONS / OPTIONAL / OPTIONEN / OPCIONES
400 bar / 5800 psi

129 729 941
Produit / Paint



129 729 908
Air



400 bar / 5800 psi
129 729 943





Air **Produit / Paint**

049 030 042



906 300 101



 $\varnothing < 09$ **# 000 094 000**
 $\varnothing \geq 09$ **# 000 094 002**

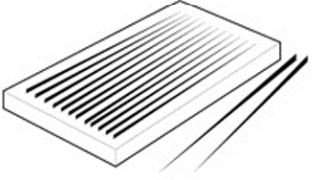

129 729 922



TABLEAU DES BUSES - TIP CHART - DÜSENTABELLE - CUADRO DE BOQUILLAS

(Buses avec porte-insert inox / Tips with stainless steel insert-holder
Düsen mit Edelstahlfassung / Boquillas con porta inserto de inox)

Buses standards / Standard tips / Standard Düsen / Boquillas estándar

		Débit d'eau Water output Wasserdurchsatz Caudal agua (l / mn)				Repères tamis pour filtre Mesh number for filter Siebgröße für Filter Índices para filtro		Largeur de jet à 25 cm / Spray fan width at 25 cm (10 ") Strahlbreite bei 25 cm Abstand / Ancho abanico à 25 cm Avec tête / with aircap / mit Zerstäuberkopf / con cabezal									
								Maxi (cm)									
Calibre Size Größe	Ø. mm	Pression / Pressure / Druck / Presión				Pistolet Gun Pistole Pistola	Pompe Pump Pumpe Bomba	9	12	17	21	25	29	33	37	44	56
		35 bar 500 psi	70 bar 1000 psi	120 bar 1740 psi	200 bar 2900 psi			Maxi (")									
								3.5	4.7	6.7	8	10	12	13	14.5	17.3	22
												Nombre gravé sur la buse / Number engraved on the tip Eingravierte Kennzahl auf der Düse / índice gravado sobre la boquilla					
02	0,15	0,07	0,10	0,13	0,17	4	2	02.034	02.054			02.114					
03	0,18	0,11	0,15	0,20	0,26	4	2	03.034	03.054	03.074			03.134				
04	0,23	0,16	0,22	0,29	0,38	4	2 ou 4	04.034	04.054	04.074	04.094	04.114	04.134				
06	0,28	0,23	0,33	0,43	0,57	4	4 ou 6	06.034	06.054	06.074	06.094	06.114	06.134	06.154			
07	0,30	0,28	0,39	0,51	0,66	6	4 ou 6							07.154			
09	0,33	0,32	0,45	0,59	0,77	6	6 ou 8	09.034	09.054	09.074	09.094	09.114	09.134	09.154	09.174		
12	0,38	0,42	0,60	0,79	1,03	6	8 ou 12			12.074	12.094	12.114	12.134	12.154	12.174		
14	0,41	0,51	0,72	0,94	1,23	12	8 ou 12		14.054	14.074	14.094	14.114	14.134	14.154	14.174		
18	0,48	0,67	0,95	1,24	1,63	12	12						18.134	18.154	18.174	18.194	
20	0,50	0,76	1,06	1,39	1,82	12	12			20.074	20.094	20.114	20.134	20.154	20.174	20.194	
25	0,56	0,94	1,33	1,74	2,28	12	15						25.134		25.174		
30	0,61	1,13	1,60	2,09	2,74	12	15					30.114	30.134	30.154	30.174	30.194	
40	0,72	1,54	2,18	2,85	3,73	12	20								40.174		
45	0,76	1,68	2,38	3,12	4,08	12	20					45.114		45.154	45.174	45.194	
100	1,04	3,96	5,68	7,33	9,47	12	20-30								100.174		100.214

Buses spéciales pour peintures hydrodiluable / Specific tips for water-based paints Spezifische Düsen für Wasserlacken / Boquillas específicas para pinturas hidrosolubles

04	0,23	0,16	0,22	0,29	0,38	4	2 ou 4	04.032	04.052	04.072	04.092	04.112					
06	0,28	0,23	0,33	0,43	0,57	4	4 ou 6	06.032	06.052	06.072	06.092	06.112	06.132	06.152			
07	0,30	0,28	0,39	0,51	0,66	6	4 ou 6							07.152			
09	0,33	0,32	0,45	0,59	0,77	6	6 ou 8	09.032	09.052	09.072	09.092	09.112	09.132	09.152			
12	0,38	0,42	0,60	0,79	1,03	6	8 ou 12			12.072	12.092	12.112	12.132	12.152	12.172		
14	0,41	0,51	0,72	0,94	1,23	12	8 ou 12		14.052	14.072	14.092	14.112	14.132	14.152	14.172		

Réglage de jet optimal / Optimum fan adjustment / Optimale Strahlregulierung / Ajuste de abanico óptimo

Pour établir la référence d'une buse, remplacer les croix par le nombre repère de la buse précédé de 134.5XX.XXX
Exemple : pour commander une buse 09.094, utiliser la référence : 134.509.094

To obtain tip part number, replace the crosses by the engraved tip number preceded by 134.5XX.XXX
Example : use part number 134.509.094 to obtain TIP N° 09.094

Die Bestell-Nr. erhält man, indem man die Kreuze durch die vorgenannte Kennzahl ersetzt : 134.5XX.XXX
Beispiel : für eine Düse 09.094 ergibt sich die Bestell-Nr. : 134.509.094

Para establecer la referencia de una boquilla reemplazar las cruces por el número de la boquilla precedido por 134.5XX.XXX
ejemplo : para pedir una boquilla 09.094 emplear la referencia : 134.509.094